

CL57-R/OL57-R  
RS485 Bus-Type Step Drive

User Manual

# Contents

<b>CHAPTER I PRODUCT INTRODUCTION .....</b>	<b>1</b>
1.1 PRODUCT INTRODUCTION .....	1
1.2 COMMUNICATION SPECIFICATIONS .....	1
1.3 PRODUCT SPECIFICATIONS.....	1
1.4 DRIVE MOUNTING DIMENSIONS.....	2
1.5 DESCRIPTION OF EACH DRIVE PART .....	2
<b>CHAPTER II DRIVE PORT AND WIRING .....</b>	<b>3</b>
2.1 DEFINITION OF DRIVE PORT .....	3
2.1.1 RS485 communication port .....	3
2.1.2 Encoder port.....	3
2.1.3 DI/DO port.....	3
2.2 WIRING .....	4
2.2.1 Drive wiring diagram.....	4
2.2.2 Description of DI/DO interface .....	5
2.2.3 Description of RS485 installation and wiring.....	6
2.2.4 Setting of dial switch .....	6
<b>CHAPTER III DESCRIPTION OF COMMUNICATION CONTROL .....</b>	<b>8</b>
3.1 POSITION MODE .....	8
3.1.1 Related parameters.....	8
3.1.2 Description of position mode.....	8
3.1.3 Description of control mode .....	8
3.2 INTERNAL MULTI-SEGMENT POSITION .....	9
3.2.1 Related parameters.....	9
3.2.2 Description of internal multi-segment position control .....	10
3.3 INTERNAL MULTI-SEGMENT VELOCITY .....	10
3.3.1 Related parameters.....	10
3.3.2 Description of internal multi-segment velocity control .....	11
3.4 HOMING MODE.....	12
3.4.1 Related parameters.....	12
3.4.2 Description of homing mode .....	12
3.4.3 Description of control steps .....	13
3.5 DETAILED PARAMETER DESCRIPTION .....	13
3.5.1 Monitoring parameters.....	13
3.5.2 DI/DO parameters.....	14
3.5.3 Communication control parameters .....	16
3.5.4 Internal multi-segment position .....	17
3.5.5 Internal multi-segment velocity .....	19
3.5.6 Factory parameters.....	20
3.6 ALARM PROCESSING .....	21
<b>CHAPTER IV DESCRIPTION OF MODBUS RTU .....</b>	<b>21</b>
4.1 PARAMETER READING COMMAND (0x03).....	21
4.2 SINGLE-REGISTER WRITING COMMAND (0x06) .....	22
4.3 MULTI-REGISTER WRITING COMMAND (0x10) .....	23
4.4 ABNORMAL RESPONSE AND ERROR CODE .....	24

## Chapter I Product Introduction

### 1.1 Product Introduction

Each step drive of this series is manufactured based on a new generation 32-bit DSP technology, which is provided with the RS485 bus control function, supports the MODBUS-RTU communication protocol and can carry up to 32 axes for multi-axis synchronous bus control. The drive is provided with 15 internal positions and 15 internal velocities, supports functions such as automatic homing, absolute/relative positioning and JOG, etc., and can be directly controlled through its touch screen or controller with an RS485 interface.

### 1.2 Communication specifications

- Communication interface: RS485;
- Communication protocol: Modbus RTU;
- Baud rate: 9600, 19200, 38400, 115200 (set by dialing SW6~SW7);
- Station No.: 1~31 (set by dialing SW1~SW5)
- Terminal resistance: 120Ω (set by dialing SW8)
- Check bit: without parity check (default), odd parity check, even parity check;

### 1.3 Product specifications

Drive model Parameter	CL57-R	OL57-R
Matched motor	42/57/60	
Supply voltage	24~48V DC	
Maximum output current	5A	
DI port input current	10~50mA	
DI port input voltage	24V DC	
Encoder	1000 ppr incremental	N/A
Insulation resistance	100MΩ	
Operating environment	Temp.: 0 °C~ 45°C. Humidity: ≤ 90% RH, without condensation. Altitude: ≤1000m. Installation environment: without corrosive and flammable gases, without oil mist or dust, etc. Vibration: < 0.5G (4.9m/s <sup>2</sup> ), 10~60 Hz (non-continuous operation).	
Storage environment	-20~65°C (without frost), < 90% RH (without condensation)	
Drive size	134*83*33	
Drive weight		

### 1.4 Drive mounting dimensions

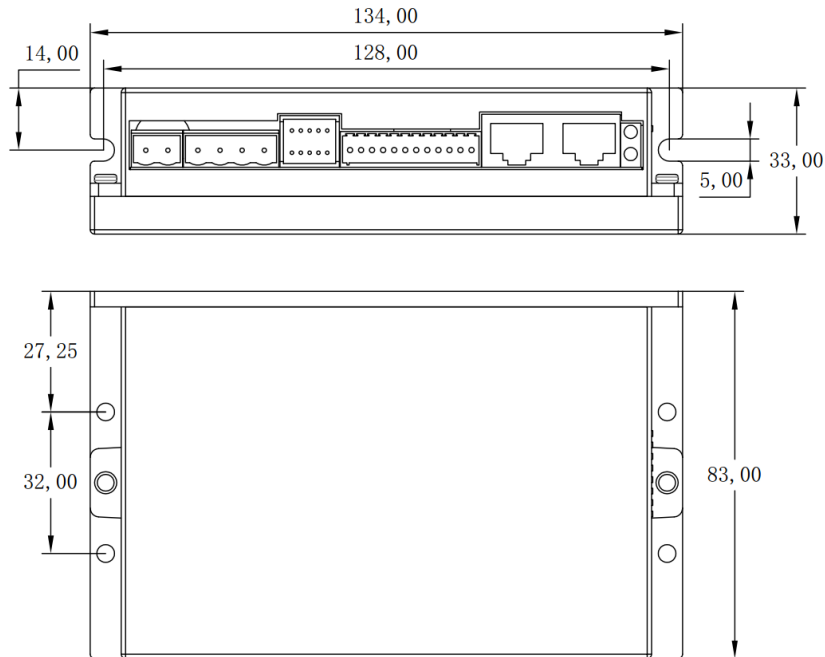

### 1.5 Description of each drive part

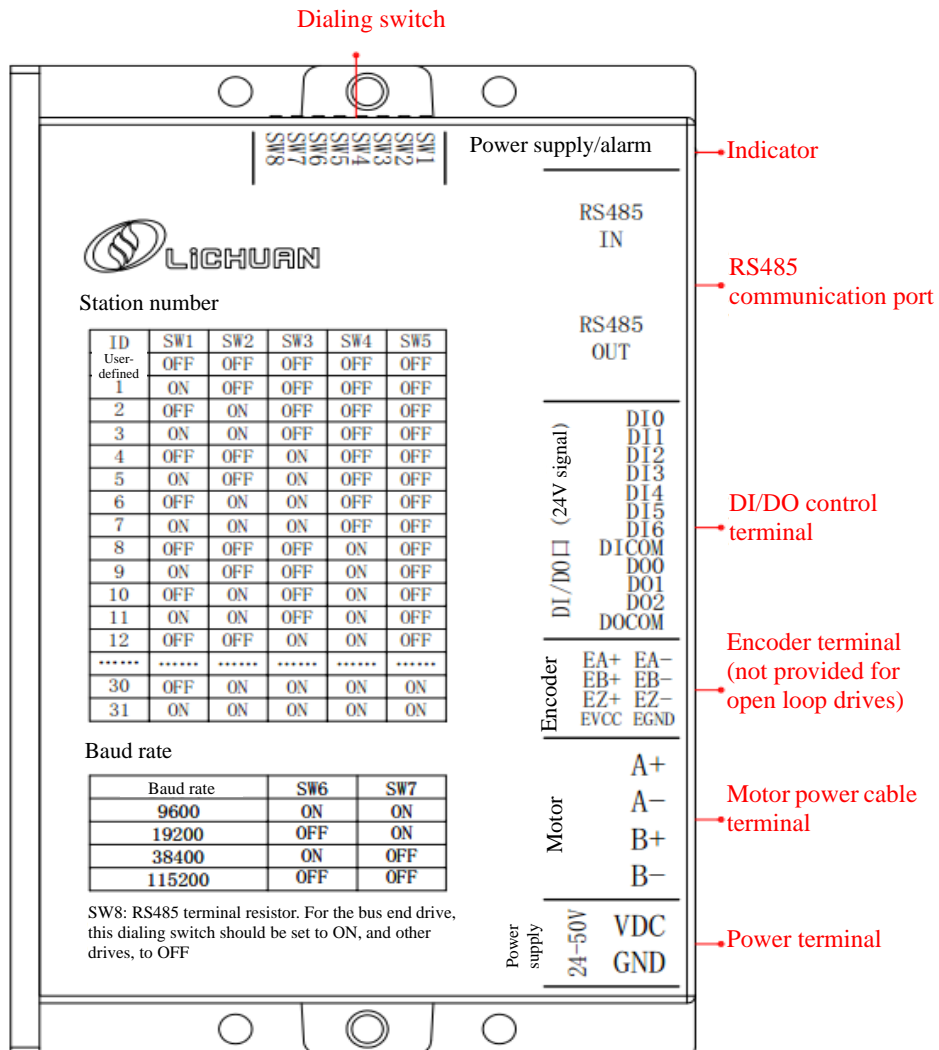

## Chapter II Drive Port and Wiring

### 2.1 Definition of drive port

#### 2.1.1 RS485 communication port

Pin	Network cable color	Signal definition
1	White/orange	485+
2	Orange	485-
3	White/green	GND
4	Blue	NC
5	White/blue	NC
6	Green	NC
7	White/brown	NC
8	Brown	NC

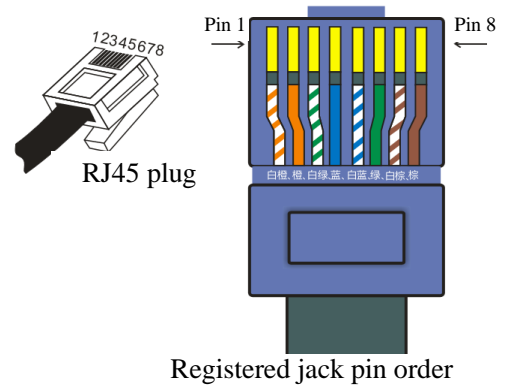

#### 2.1.2 Encoder port

Pin	Definition	Description
1	EA+	Positive / negative terminal of encoder A-phase
2	EA-	
3	EB+	Positive / negative terminal of encoder B-phase
4	EB-	
5	EZ+	Positive / negative terminal of encoder Z-phase
6	EZ-	
7	EVCC	Positive terminal of encoder power supply (5V)
8	EGND	Negative terminal of encoder power supply (5V)
9	NC	Not connected
10	NC	Not connected

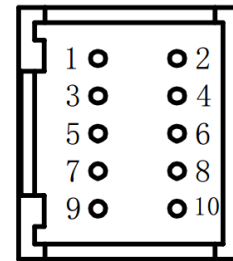

Encoder wire terminal

#### 2.1.3 DI/DO port

Pin	Definition	Description
1	<b>DI0</b>	Single-end input port; Effective operating voltage 24V
2	<b>DI1</b>	
3	<b>DI2</b>	
4	<b>DI3</b>	
5	<b>DI4</b>	
6	<b>DI5</b>	
7	<b>DI6</b>	
8	<b>DICOM</b>	Common terminal of input port; Compatible for common anode/common cathode connection
9	<b>DO0</b>	Single-end output port
10	<b>DO1</b>	
11	<b>DO2</b>	
12	<b>DOCOM</b>	Common terminal of output port; Only connecting to the negative terminal of the power supply is allowed

## 2.2 Wiring

### 2.2.1 Drive wiring diagram

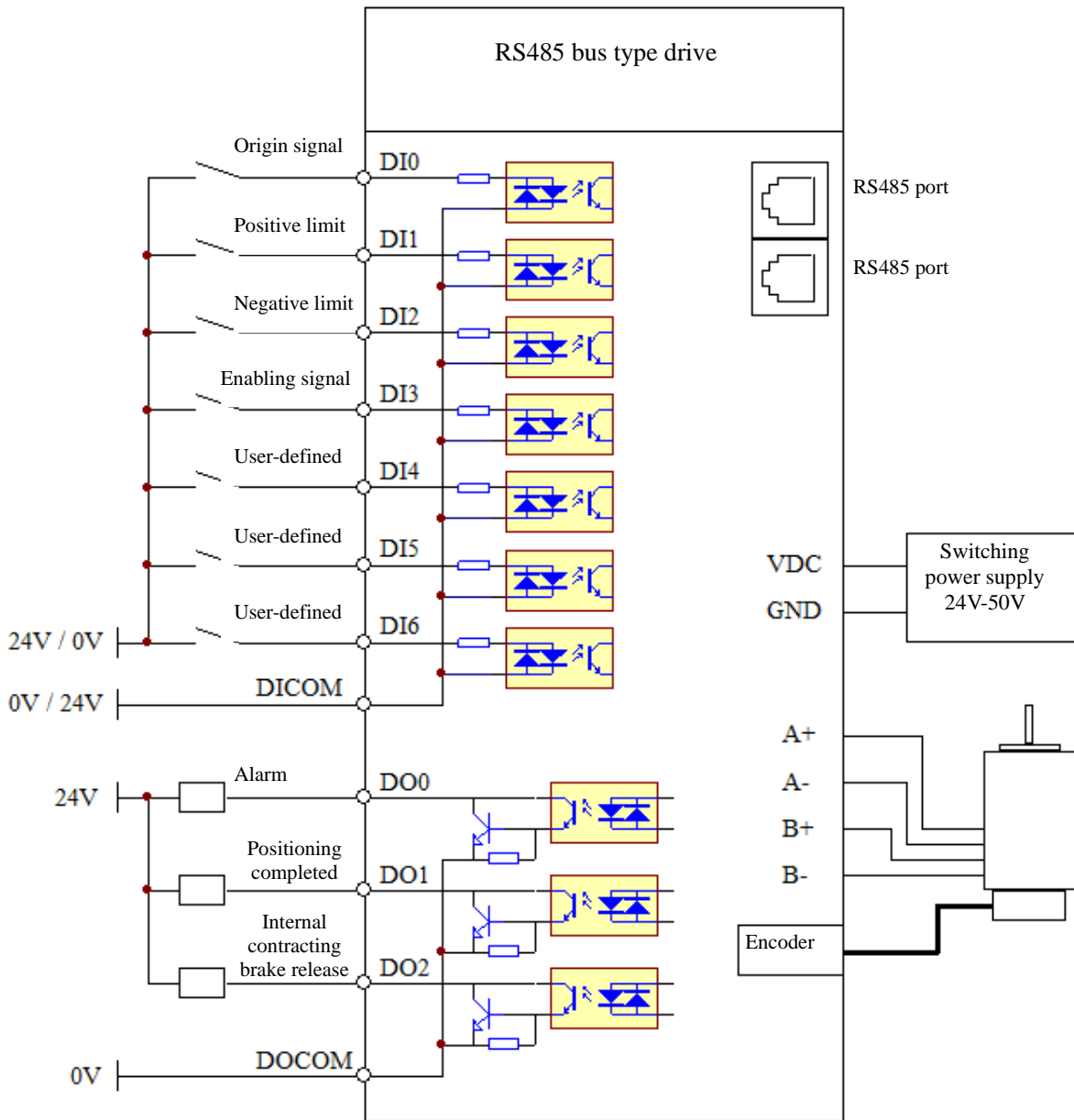

- Note: 1. The DI input voltage is 24V. If the voltage exceeds 24V, a current limiting resistor shall be used;
2. The wiring of the DI input port supports common anode/common cathode connection. When DICOM is 24V, the connection of the DI port to 0V is effective, and when DICOM is 0V, the connection of the DI port to 24V is effective.
3. The common terminal DOCOM of the DO port is only allowed to be connected to 0V rather than 24V.

## 2.2.2 Description of DI/DO interface

Each drive of this series has 7 programmable input interfaces and 3 programmable output interfaces. The corresponding functions of each DI/DO can be configured through the RS485 bus and the upper computer debugging software. The relevant configuration parameters are shown in the following table:

No.	Address (decimal)	Description	Default value
PA_010	16	Normally open/normally closed switching of DI terminal	0
PA_011	17	Configured DI Input Port 0	1
PA_012	18	Configured DI Input Port 1	2
PA_013	19	Configured DI Input Port 2	3
PA_014	20	Configured DI Input Port 3	0
PA_015	21	Configured DI Input Port 4	0
PA_016	22	Configured DI Input Port 5	0
PA_017	23	Configured DI Input Port 6	0
PA_01A	26	Input port filtering coefficient	2
PA_01B	27	Normally open/normally closed switching of DO terminal	0
PA_01C	28	Configured DO Output Port 0	1
PA_01D	29	Configured DO Output Port 1	0
PA_01E	30	Configured DO Output Port 2	0
PA_01F	31	Forced output of output port	0

Function command table of DI port:

Command value	Function description	Command value	Function description
0	Undefined	10	Negative JOG
1	Origin signal	11	Homing triggering
2	Positive limit	12	Location path triggering
3	Negative limit	13	Velocity path triggering
4	Signal release	14	Path Selector Switch 0
5	Signal stop	15	Path Selector Switch 1
6	Forced emergency stop	16	Path Selector Switch 2
9	Positive JOG	17	Path Selector Switch 3

Function command table of DO port:

Command value	Function description	Command value	Function description
0	Undefined	5	Release signal of internal contracting brake
1	Alarm output	9	Forced Output Control 1
2	Motor running	10	Forced Output Control 2
3	Homing completed	11	Forced Output Control 3
4	In-place signal		

Forced output control mode of DO port:

Bit corresponding to PA_01F	Description
Bit0	Output port set as 9 by control function command. 0: Off, 1: On
Bit1	Output port set as 10 by control function command. 0: Off, 1: On
Bit2	Output port set as 11 by control function command. 0: Off, 1: On

### 2.2.3 Description of RS485 installation and wiring

Each RS485 bus drive of this series has 2 standard RJ45 network interfaces, in which Pins 1 and 2 correspond to 485+ and 485- signal wires, respectively, and Pin 3, to GND. It is recommended to use a shielded twisted-pair or network cable as the transmission medium for communication. All nodes shall be directly connected to this pair of public transmission medium and arranged in parallel for receiving or sending data information. For the drive at the end of the bus, the dial switch SW8 shall be set to ON, indicating that a terminating resistance shall be connected for termination in order to prevent the signal sent by the node on the network from being reflected when reaching the end of the cable.

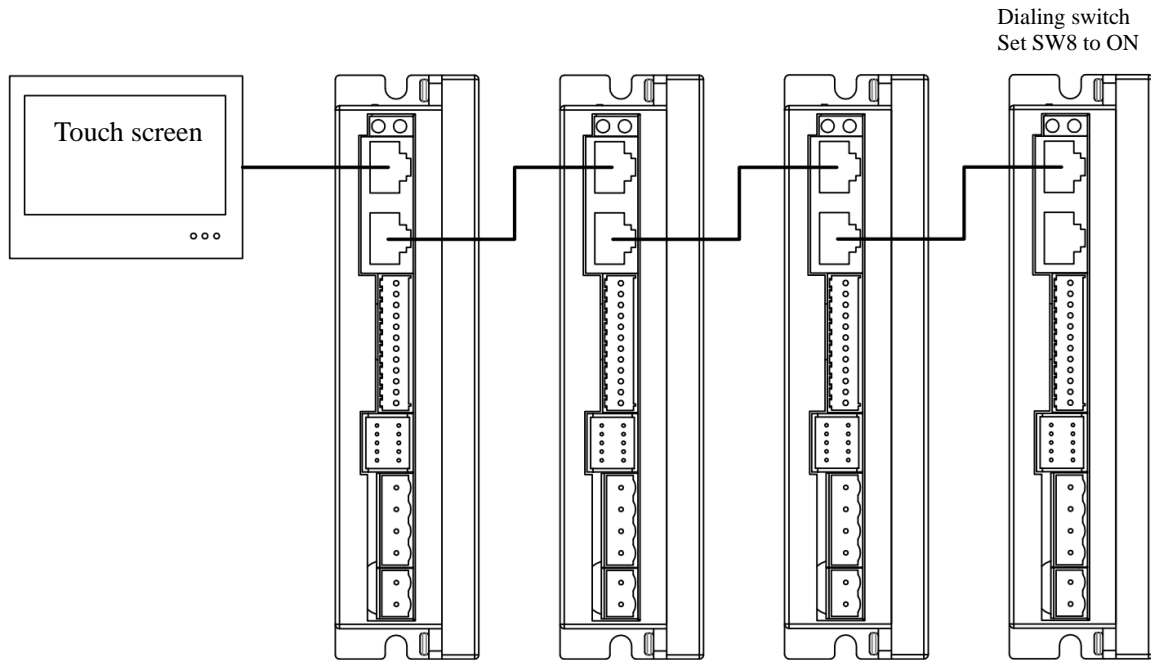

### 2.2.4 Setting of dial switch

Each CANopen bus drive of this series has 8 dial switch bits for setting the CANopen station number, communication baud rate, and terminal resistance. The distribution is shown in the following figure:

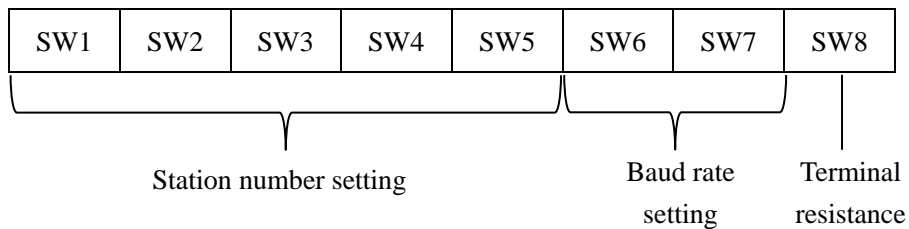

Baud rate setting:

Baud rate	SW6	SW7
9600	ON	ON
19200	OFF	ON
38400	ON	OFF
115200	OFF	OFF

Terminal resistance setting:

When SW8 is set to ON, a terminal resistance of 120Ω will be connected between the signal wires to prevent the signal sent by the node on the network from reflecting when reaching the end of the cable.



Drive station number setting:

Station number	SW1	SW2	SW3	SW4	SW5	Station number	SW1	SW2	SW3	SW4	SW5
User-defined	OFF	OFF	OFF	OFF	OFF	16	OFF	OFF	OFF	OFF	ON
1	ON	OFF	OFF	OFF	OFF	17	ON	OFF	OFF	OFF	ON
2	OFF	ON	OFF	OFF	OFF	18	OFF	ON	OFF	OFF	ON
3	ON	ON	OFF	OFF	OFF	19	ON	ON	OFF	OFF	ON
4	OFF	OFF	ON	OFF	OFF	20	OFF	OFF	ON	OFF	ON
5	ON	OFF	ON	OFF	OFF	21	ON	OFF	ON	OFF	ON
6	OFF	ON	ON	OFF	OFF	22	OFF	ON	ON	OFF	ON
7	ON	ON	ON	OFF	OFF	23	ON	ON	ON	OFF	ON
8	OFF	OFF	OFF	ON	OFF	24	OFF	OFF	OFF	ON	ON
9	ON	OFF	OFF	ON	OFF	25	ON	OFF	OFF	ON	ON
10	OFF	ON	OFF	ON	OFF	26	OFF	ON	OFF	ON	ON
11	ON	ON	OFF	ON	OFF	27	ON	ON	OFF	ON	ON
12	OFF	OFF	ON	ON	OFF	28	OFF	OFF	ON	ON	ON
13	ON	OFF	ON	ON	OFF	29	ON	OFF	ON	ON	ON
14	OFF	ON	ON	ON	OFF	30	OFF	ON	ON	ON	ON
15	ON	ON	ON	ON	OFF	31	ON	ON	ON	ON	ON

## Chapter III Description of Communication Control

### 3.1 Position mode

#### 3.1.1 Related parameters

No.	Address (decimal)	Name	Setting range	Data Type	Property
PA_033	51	Positioning running starting velocity (r/min)	0~3000	UNSIGNED16	RW
PA_034	52	Positioning running acceleration time (ms)	0~2000	UNSIGNED16	RW
PA_035	53	Positioning running deceleration time (ms)	0~2000	UNSIGNED16	RW
PA_036	54	Positioning running velocity (r/min)	0~3000	UNSIGNED16	RW
PA_037	55	(Pulse) H of positioning target	-2147483648~ 2147483647	INTEGER32	RW
PA_038	56	(Pulse) L of positioning target			
PA_04E	78	Control word	0~127	UNSIGNED16	RW
PA_04	4	Operation status		UNSIGNED16	RO
PA_08	8	(Pulse) H of current position		INTEGER32	RO
PA_09	9	(Pulse) L of current position			
PA_0A	10	Current velocity (r/min)		INTEGER16	RO

#### 3.1.2 Description of position mode

The position mode gives the motion parameters through the master station: starting velocity (0x0033), acceleration time (0x0034), deceleration time (0x0035), running velocity (0x0036), and positioning target (0x0037, 0x0038), and then the drive builds the motion path according to these parameters to achieve accurate position control. The motion curve is shown in the following figure:

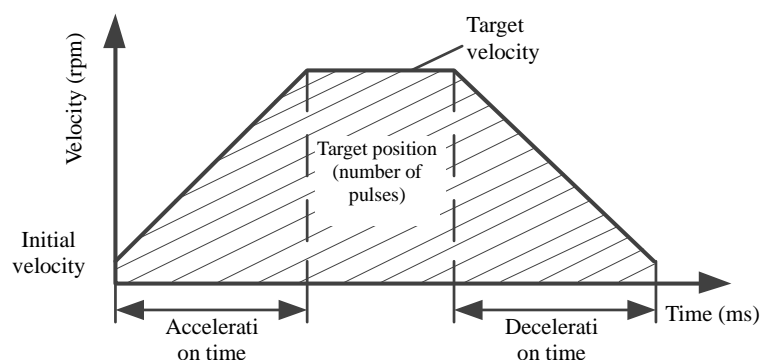

#### 3.1.3 Description of control mode

1. Description of control word: The control is realized by Bit0-Bit6 of the control word (0x004E). The corresponding functions of each bit of the control word are shown in the following table:

Control word bit	Functions	Description
Bit0	For positioning control bit	0: Noneffective ; 1: Effective; (resetting to zero not required, just reset to 1)
Bit1	Positioning mode bit	0: Relative position; 1: Absolute position;
Bit2	Switching mode	0: Ignoring the new command during a positioning motion; 1: Interrupting the current positioning motion to perform a new command
Bit3	JOG control bit	0: Noneffective; 1: Effective
Bit4	Homing control bit	0: Noneffective; 1: Effective; (resetting to zero not required, just reset to 1)
Bit5	Stopping control bit	0: Noneffective; 1: Effective
Bit6	Emergency stop control bit	0: Noneffective; 1: Effective

2. Description of status word: The current motion status can be obtained by monitoring Bit0-Bit6 of the status word (0x0004), as shown in the following table:

Status word bit	Functions	Status word bit	Functions
Bit0	In place	Bit4	Motor enabling
Bit1	Homing completed	Bit5	Positive software limit
Bit2	Motor running	Bit6	Negative software limit
Bit3	Failure		

## 3.2 Internal multi-segment position

### 3.2.1 Related parameters

No.	Address (decimal)	Name	Setting range	Data Type	Property
PA_050	80	(Pulse) H of Positioning Path 0	-2147483648~ 2147483647	INTEGER32	RW
PA_051	81	(Pulse) L of Positioning Path 0			
PA_052	82	Positioning velocity of Positioning Path 0	0~3000	UNSIGNED16	RW
PA_053	83	Acceleration time of Positioning Path 0	0~2000	UNSIGNED16	RW
PA_054	84	Deceleration time of Positioning Path 0	0~2000	UNSIGNED16	RW
PA_056	86	(Pulse) H of Positioning Path 1	-2147483648~ 2147483647	INTEGER32	RW
PA_057	87	(Pulse) L of Positioning Path 1			
PA_058	88	Positioning velocity of Positioning Path 1	0~3000	UNSIGNED16	RW
PA_059	89	Acceleration time of Positioning Path 1	0~2000	UNSIGNED16	RW
PA_05A	90	Deceleration time of Positioning Path 1	0~2000	UNSIGNED16	RW
.....					
PA_0AA	170	(Pulse) H of Positioning Path 15	-2147483648~ 2147483647	INTEGER32	RW
PA_0AB	171	(Pulse) L of Positioning Path 15			
PA_0AC	172	Positioning velocity of Positioning Path 15	0~3000	UNSIGNED16	RW
PA_0AD	173	Acceleration time of Positioning Path 15	0~2000	UNSIGNED16	RW
PA_0AE	174	Deceleration time of Positioning Path 15	0~2000	UNSIGNED16	RW
PA_04	4	Operation status		UNSIGNED16	RO
PA_08	8	(Pulse) H of current position		INTEGER32	RO
PA_09	9	(Pulse) L of current position			
PA_0A	10	Current velocity (r/min)		INTEGER16	RO

### 3.2.2 Description of internal multi-segment position control

1. The internal multi-segment position can only run after being selected and triggered through the DI port, see the following details:

No.	Address (decimal)	Set value	Description
PA_013	19	12	DI2 is configured as position path triggering
PA_014	20	14	DI3 is configured as Path Selector Switch 0
PA_015	21	15	DI4 is configured as Path Selector Switch 1
PA_016	22	16	DI5 is configured as Path Selector Switch 2
PA_017	23	17	DI6 is configured as Path Selector Switch 3

After configuring the DI port according to the above table, select the position segment through DI3-DI4, and then use DI2 to trigger (rising edge) running of the position segment. See the following table:

Selector Switch 0	Selector Switch 1	Selector Switch 2	Selector Switch 3	Corresponding positioning path	Positioning pulse address	Positioning velocity address	Acceleration time address	Deceleration time address
OFF	OFF	OFF	OFF	0	80/81	82	83	84
ON	OFF	OFF	OFF	1	86/87	88	89	90
OFF	ON	OFF	OFF	2	92/93	94	95	96
ON	ON	OFF	OFF	3	98/99	100	101	102
OFF	OFF	ON	OFF	4	104/105	106	107	108
ON	OFF	ON	OFF	5	110/111	112	113	114
OFF	ON	ON	OFF	6	116/117	118	119	120
ON	ON	ON	OFF	7	122/123	124	125	126
OFF	OFF	OFF	ON	8	128/129	130	131	132
ON	OFF	OFF	ON	9	134/135	136	137	138
OFF	ON	OFF	ON	10	140/141	142	143	144
ON	ON	OFF	ON	11	146/147	148	149	150
OFF	OFF	ON	ON	12	152/153	154	155	156
ON	OFF	ON	ON	13	158/159	160	161	162
OFF	ON	ON	ON	14	164/165	166	167	168
ON	ON	ON	ON	15	170/171	172	173	174

2. Setting of internal multi-segment position mode

No.	Address (decimal)	Function definition	Default value	Description
PA_026	38	Internal multi-segment position Triggering mode	0	0: Interrupting the current positioning motion to perform a new command; 1: Ignoring the new command during a positioning motion;
PA_04A	74	Internal multi-segment position Setting of absolute/relative position mode	0	0: Relative position mode 1: Absolute position mode

### 3.3 Internal multi-segment velocity

#### 3.3.1 Related parameters

No.	Address (decimal)	Name	Setting range	Data Type	Property
PA_0B0	176	Running velocity of Velocity Path 0	-3000~3000	INTEGER16	RW

PA_0B1	177	Acceleration time of Velocity Path 0	0~2000	UNSIGNED16	RW
PA_0B2	178	Deceleration time of Velocity Path 0	0~2000	UNSIGNED16	RW
PA_0B3	179	Running velocity of Velocity Path 1	-3000~3000	INTEGER16	RW
PA_0B4	180	Acceleration time of Velocity Path 1	0~2000	UNSIGNED16	RW
PA_0B5	181	Deceleration time of Velocity Path 1	0~2000	UNSIGNED16	RW
.....					
PA_0DD	221	Running velocity of Velocity Path 15	-3000~3000	INTEGER16	RW
PA_0DE	222	Acceleration time of Velocity Path 15	0~2000	UNSIGNED16	RW
PA_0DF	223	Deceleration time of Velocity Path 15	0~2000	UNSIGNED16	RW
PA_04	4	Operation status		UNSIGNED16	RO
PA_0A	10	Current velocity (r/min)		INTEGER16	RO

### 3.3.2 Description of internal multi-segment velocity control

The internal multi-segment position can only run after being selected and triggered through the DI port, see the following details:

No.	Address (decimal)	Set value	Description
PA_013	19	13	DI2 is configured as velocity path triggering
PA_014	20	14	DI3 is configured as Path Selector Switch 0
PA_015	21	15	DI4 is configured as Path Selector Switch 1
PA_016	22	16	DI5 is configured as Path Selector Switch 2
PA_017	23	17	DI6 is configured as Path Selector Switch 3

After configuring the DI port according to the above table, select the position segment through DI3-DI4, and then use DI2 to trigger (**On for operation and Off for stop**) running of the velocity segment. See the following table:

Selector Switch 0	Selector Switch 1	Selector Switch 2	Selector Switch 3	Corresponding velocity path	16th segment of displacement address	Acceleration time address	Deceleration time address
OFF	OFF	OFF	OFF	0	176	177	178
ON	OFF	OFF	OFF	1	179	180	181
OFF	ON	OFF	OFF	2	182	183	184
ON	ON	OFF	OFF	3	185	186	187
OFF	OFF	ON	OFF	4	188	189	190
ON	OFF	ON	OFF	5	191	192	193
OFF	ON	ON	OFF	6	194	195	196
ON	ON	ON	OFF	7	197	198	199
OFF	OFF	OFF	ON	8	200	201	202
ON	OFF	OFF	ON	9	203	204	205
OFF	ON	OFF	ON	10	206	207	208
ON	ON	OFF	ON	11	209	210	211
OFF	OFF	ON	ON	12	212	213	214
ON	OFF	ON	ON	13	215	216	217
OFF	ON	ON	ON	14	218	219	220
ON	ON	ON	ON	15	221	222	223

## 3.4 Homing mode

### 3.4.1 Related parameters

No.	Address (decimal)	Name	Setting range	Data Type	Property
PA_040	64	Homing mode	17, 18, 24, 29, 35	UNSIGNED 16	RW
PA_041	65	Homing velocity	0~3000	UNSIGNED16	RW
PA_042	66	Homing creep velocity	0~3000	UNSIGNED16	RW
PA_043	67	Homing acceleration / deceleration time	0~2000	INTEGER16	RW
PA_044	68	Origin Offset H	-2147483648~ 2147483647	INTEGER32	RW
PA_045	69	Origin Offset L			
PA_04	4	Operation status		UNSIGNED16	RO
PA_08	8	(Pulse) H of current position		INTEGER32	RO
PA_09	9	(Pulse) L of current position			
PA_0A	10	Current velocity (r/min)		INTEGER16	RO

### 3.4.2 Description of homing mode

**1. Negative limit mode (PA\_040=17):** After homing is allowed, the motor will run in the negative direction at the homing velocity (PA\_041). It will decelerate and stop when the negative limit switch is sensed, then it will run in the positive direction at the homing velocity (PA\_041) for a certain distance and decelerate and stop. Then it will run in the negative direction at a homing creep velocity (PA\_042). When the negative limit switch is sensed, the motor will stop, indicating that the homing operation is completed.

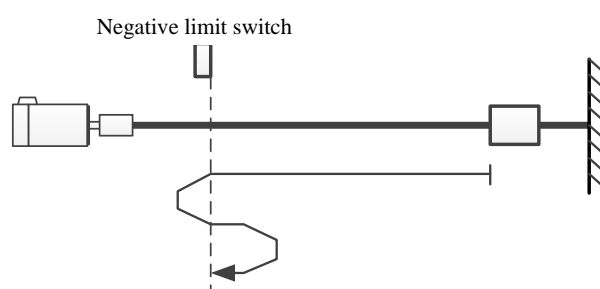

**2. Positive limit mode (PA\_040=18):** After homing is allowed, the motor will run in the positive direction at the homing velocity (PA\_041). It will decelerate and stop when the positive limit switch is sensed, then it will run in the negative direction at the homing velocity (PA\_041) for a certain distance and decelerate and stop. Then it will run in the positive direction at a homing creep velocity (PA\_042). When the positive limit switch is sensed, the motor will stop, indicating that the homing operation is completed.

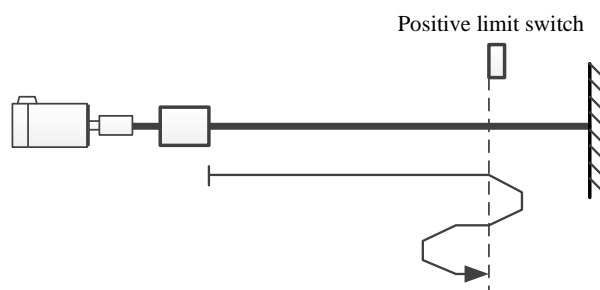

**3. Positive origin mode (PA\_040=24):** After homing is allowed, the motor will run in the positive direction at the homing velocity (PA\_041). It will decelerate and stop when the origin switch is sensed, then it will run in the negative direction at the homing velocity (PA\_041) for a certain distance and decelerate and stop. Then it will run in the positive direction at a homing creep velocity (PA\_042). When the origin switch is sensed, the motor will stop, indicating that the homing operation is completed.

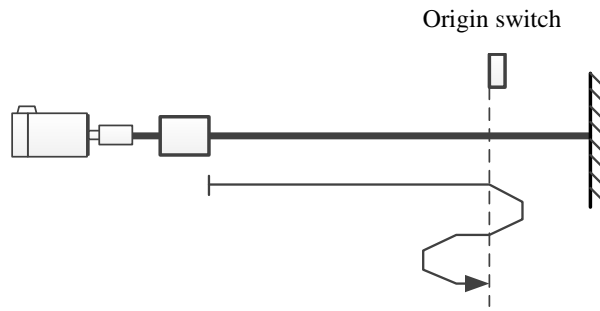

**4. Negative origin mode (PA\_040=29):** After homing is allowed, the motor will run in the negative direction at the homing velocity (PA\_041). It will decelerate and stop when leaving the origin switch is sensed. Then it will run in the positive direction at a homing creep velocity (PA\_042). When the origin switch is sensed, the motor will stop, indicating that the homing operation is completed.

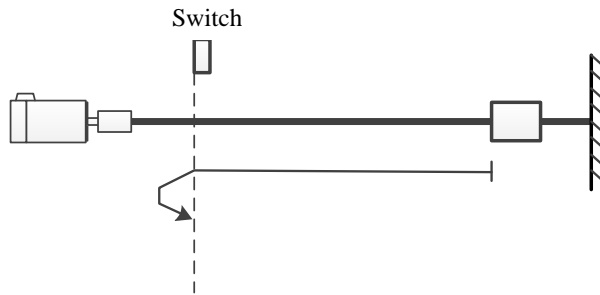

**5. Setting the current position as the origin (PA\_040=35):** After homing is allowed, clear the current position directly, and then output the homing completed signal.

### 3.4.3 Description of control steps

1. First, check the default DI port configuration for being changed;

No.	Address (decimal)	Set value	Description
PA_011	17	1	DI0 is configured as the origin switch
PA_012	18	2	DI1 is configured as the positive limit switch
PA_013	19	3	DI2 is configured as the negative limit switch

2. Set the related homing parameters: homing mode (PA\_040), homing velocity (PA\_041), homing creep velocity (PA\_042), homing acceleration / deceleration time (PA\_043) and homing offset (PA\_044, PA\_045). After setting, use **Bit4 of the control word (PA\_04E)** to trigger (rising edge) homing starting. When the homing operation is completed, the homing completion signal will be output.

## 3.5 Detailed parameter description

### 3.5.1 Monitoring parameters

No.	Register address (decimal)	Item	Description	Property
PA_001	1	Software version	Hardware version	(RO)
PA_002	2	Hardware version	Software version	(RO)

User Manual of CL57-R / OL57-R Bus-Type Step Drive

PA_004	4	Operation status	<table border="1"> <thead> <tr> <th>Code</th> <th>Operation status</th> </tr> </thead> <tbody> <tr> <td>Bit0</td> <td>In place</td> </tr> <tr> <td>Bit1</td> <td>Homing completed</td> </tr> <tr> <td>Bit2</td> <td>Motor running</td> </tr> <tr> <td>Bit3</td> <td>Failure</td> </tr> <tr> <td>Bit4</td> <td>Motor enabling</td> </tr> <tr> <td>Bit5</td> <td>Positive software limit</td> </tr> <tr> <td>Bit6</td> <td>Negative software limit</td> </tr> </tbody> </table>	Code	Operation status	Bit0	In place	Bit1	Homing completed	Bit2	Motor running	Bit3	Failure	Bit4	Motor enabling	Bit5	Positive software limit	Bit6	Negative software limit	(RO)
			Code	Operation status																
			Bit0	In place																
			Bit1	Homing completed																
			Bit2	Motor running																
			Bit3	Failure																
			Bit4	Motor enabling																
			Bit5	Positive software limit																
Bit6	Negative software limit																			
<table border="1"> <thead> <tr> <th>Fault code</th> <th>Content</th> </tr> </thead> <tbody> <tr> <td>0x01</td> <td>Overcurrent</td> </tr> <tr> <td>0x02</td> <td>Overvoltage</td> </tr> <tr> <td>0x03</td> <td>Undervoltage</td> </tr> </tbody> </table>	Fault code	Content	0x01	Overcurrent	0x02	Overvoltage	0x03	Undervoltage												
Fault code	Content																			
0x01	Overcurrent																			
0x02	Overvoltage																			
0x03	Undervoltage																			
<table border="1"> <thead> <tr> <th>Code</th> <th>Status</th> </tr> </thead> <tbody> <tr> <td>Bit0</td> <td>DI0</td> </tr> <tr> <td>Bit1</td> <td>DI1</td> </tr> <tr> <td>Bit2</td> <td>DI2</td> </tr> <tr> <td>Bit3</td> <td>DI3</td> </tr> <tr> <td>Bit4</td> <td>DI4</td> </tr> <tr> <td>Bit5</td> <td>DI5</td> </tr> </tbody> </table>	Code	Status	Bit0	DI0	Bit1	DI1	Bit2	DI2	Bit3	DI3	Bit4	DI4	Bit5	DI5						
Code	Status																			
Bit0	DI0																			
Bit1	DI1																			
Bit2	DI2																			
Bit3	DI3																			
Bit4	DI4																			
Bit5	DI5																			
<table border="1"> <thead> <tr> <th>Code</th> <th>Status</th> </tr> </thead> <tbody> <tr> <td>Bit0</td> <td>DO0</td> </tr> <tr> <td>Bit1</td> <td>DO1</td> </tr> <tr> <td>Bit2</td> <td>DO2</td> </tr> </tbody> </table>	Code	Status	Bit0	DO0	Bit1	DO1	Bit2	DO2												
Code	Status																			
Bit0	DO0																			
Bit1	DO1																			
Bit2	DO2																			
PA_008	8	Current position H	Given command position under an open loop, Feedback position under a closed loop;	(RO)																
PA_009	9	Current position L																		
PA_00A	10	Current velocity			Unit: r/min	(RO)														

### 3.5.2 DI/DO parameters

No.	Register address (decimal)	Item	Description	Setting range																
PA_010	16	Normally open/normally closed switching of DI terminal	<table border="1"> <thead> <tr> <th>Code</th> <th>Status</th> </tr> </thead> <tbody> <tr> <td>Bit0</td> <td>DI0</td> </tr> <tr> <td>Bit1</td> <td>DI1</td> </tr> <tr> <td>Bit2</td> <td>DI2</td> </tr> <tr> <td>Bit3</td> <td>DI3</td> </tr> <tr> <td>Bit4</td> <td>DI4</td> </tr> <tr> <td>Bit5</td> <td>DI5</td> </tr> <tr> <td>Bit6</td> <td>DI6</td> </tr> </tbody> </table>	Code	Status	Bit0	DI0	Bit1	DI1	Bit2	DI2	Bit3	DI3	Bit4	DI4	Bit5	DI5	Bit6	DI6	0~127
			Code	Status																
			Bit0	DI0																
			Bit1	DI1																
			Bit2	DI2																
			Bit3	DI3																
			Bit4	DI4																
			Bit5	DI5																
Bit6	DI6																			
0: Normally open; 1: Normally closed																				



PA_011	17	DI Input Port 0	<table border="1"> <thead> <tr> <th>Code</th> <th>Functions</th> </tr> </thead> <tbody> <tr> <td>0x00</td> <td>Undefined</td> </tr> <tr> <td>0x01</td> <td>Origin signal</td> </tr> <tr> <td>0x02</td> <td>Positive limit</td> </tr> <tr> <td>0x03</td> <td>Negative limit</td> </tr> <tr> <td>0x04</td> <td>Signal release</td> </tr> <tr> <td>0x05</td> <td>Signal stop</td> </tr> <tr> <td>0x06</td> <td>Forced emergency stop</td> </tr> <tr> <td>0x09</td> <td>Positive JOG</td> </tr> <tr> <td>0x0A</td> <td>Negative JOG</td> </tr> <tr> <td>0x0B</td> <td>Homing triggering</td> </tr> <tr> <td>0x0C</td> <td>Location path triggering</td> </tr> <tr> <td>0x0D</td> <td>Velocity path triggering</td> </tr> <tr> <td>0x0E</td> <td>Path Address 0</td> </tr> <tr> <td>0x0F</td> <td>Path Address 1</td> </tr> <tr> <td>0x10</td> <td>Path Address 2</td> </tr> <tr> <td>0x11</td> <td>Path Address 3</td> </tr> </tbody> </table>	Code	Functions	0x00	Undefined	0x01	Origin signal	0x02	Positive limit	0x03	Negative limit	0x04	Signal release	0x05	Signal stop	0x06	Forced emergency stop	0x09	Positive JOG	0x0A	Negative JOG	0x0B	Homing triggering	0x0C	Location path triggering	0x0D	Velocity path triggering	0x0E	Path Address 0	0x0F	Path Address 1	0x10	Path Address 2	0x11	Path Address 3	0~17
Code	Functions																																					
0x00	Undefined																																					
0x01	Origin signal																																					
0x02	Positive limit																																					
0x03	Negative limit																																					
0x04	Signal release																																					
0x05	Signal stop																																					
0x06	Forced emergency stop																																					
0x09	Positive JOG																																					
0x0A	Negative JOG																																					
0x0B	Homing triggering																																					
0x0C	Location path triggering																																					
0x0D	Velocity path triggering																																					
0x0E	Path Address 0																																					
0x0F	Path Address 1																																					
0x10	Path Address 2																																					
0x11	Path Address 3																																					
PA_012	18	DI Input Port 1	0~17																																			
PA_013	19	DI Input Port 2	0~17																																			
PA_014	20	DI Input Port 3	0~17																																			
PA_015	21	DI Input Port 4	0~17																																			
PA_016	22	DI Input Port 5	0~17																																			
PA_017	23	DI Input Port 6	0~17																																			
PA_01A	26	Input port filtering coefficient	Input port filtering coefficient	0~1024																																		
PA_01B	27	Normally open/normally closed switching of DO terminal	<table border="1"> <thead> <tr> <th>Code</th> <th>Status</th> </tr> </thead> <tbody> <tr> <td>Bit0</td> <td>DO0</td> </tr> <tr> <td>Bit1</td> <td>DO1</td> </tr> <tr> <td>Bit2</td> <td>DO2</td> </tr> </tbody> </table> <p>0: Normally open; 1: Normally closed</p>	Code	Status	Bit0	DO0	Bit1	DO1	Bit2	DO2	0~7																										
Code	Status																																					
Bit0	DO0																																					
Bit1	DO1																																					
Bit2	DO2																																					
PA_01C	28	DO Output Port 0	<table border="1"> <thead> <tr> <th>Code</th> <th>Functions</th> </tr> </thead> <tbody> <tr> <td>0x00</td> <td>N/A</td> </tr> <tr> <td>0x01</td> <td>Alarm output</td> </tr> <tr> <td>0x02</td> <td>Motor running</td> </tr> <tr> <td>0x03</td> <td>Homing completed</td> </tr> <tr> <td>0x04</td> <td>In-place signal</td> </tr> <tr> <td>0x05</td> <td>Signal of internal contracting brake</td> </tr> </tbody> </table>	Code	Functions	0x00	N/A	0x01	Alarm output	0x02	Motor running	0x03	Homing completed	0x04	In-place signal	0x05	Signal of internal contracting brake	0~3																				
Code	Functions																																					
0x00	N/A																																					
0x01	Alarm output																																					
0x02	Motor running																																					
0x03	Homing completed																																					
0x04	In-place signal																																					
0x05	Signal of internal contracting brake																																					
PA_01D	29	DO Output Port 1	0~3																																			
PA_01E	30	DO Output Port 2	0~3																																			
PA_01F	31	Forced output of output port	<table border="1"> <thead> <tr> <th>Code</th> <th>DO function code</th> </tr> </thead> <tbody> <tr> <td>Bit0</td> <td>0x09</td> </tr> <tr> <td>Bit1</td> <td>0x0A</td> </tr> <tr> <td>Bit2</td> <td>0x0B</td> </tr> </tbody> </table> <p>0: Normally open; 1: Normally closed</p> <p>Note: The functions of the output port must be set according to the corresponding function codes, and the output is only allowed after connecting to the corresponding bit;</p>	Code	DO function code	Bit0	0x09	Bit1	0x0A	Bit2	0x0B	0~7																										
Code	DO function code																																					
Bit0	0x09																																					
Bit1	0x0A																																					
Bit2	0x0B																																					

### 3.5.3 Communication control parameters

No.	Register address (decimal)	Item	Description	Setting range
PA_020	32	485 ID	Customized station number	0~254
PA_021	33	485-data type selection	0: 8-bit data, without parity check, 1 stop bit; 1: 8-bit data, without parity check, 2 stop bits; 2: 8-bit data, even parity check, 1 stop bit; 3: 8-bit data, odd parity check, 1 stop bit;	0~3
PA_022	34	Default direction setting	0: Default; 1: Negative;	0~1
PA_023	35	Subdivision setting	Subdivision setting	400~51200
PA_024	36	Limited parking	0: Stop; 1: Forced emergency stop;	0~1
PA_025	37	Effective bit of software limit	0: Noneffective; 1: Effective; Note: The software limit is only effective after the successful homing operation;	0~1
PA_26	38	Internal multi-segment position Triggering mode	0: Interrupting the current positioning motion to perform a new command; 1: Ignoring the new command during a positioning motion;	
PA_030	48	JOG running velocity	Unit: r/min	-3000~3000
PA_031	49	JOG running acceleration time	Unit: ms	0~2000
PA_032	50	JOG running deceleration time	Unit: ms	0~2000
PA_033	51	Positioning running starting velocity	Unit: r/min	0~3000
PA_034	52	Positioning running acceleration time	Unit: ms	0~2000
PA_035	53	Positioning running deceleration time	Unit: ms	0~2000
PA_036	54	Positioning running velocity	Unit: r/min	0~3000
PA_037	55	Positioning target H	Unit: pulse	-2147483648~2147483647
PA_038	56	Positioning target L		
PA_040	64	Homing mode	17: Negative limit approaching; 18: Positive limit approaching; 24: Positive limit origin approaching; 29: Negative limit origin approaching; 35: The current position is the origin;	17~35
PA_041	65	Homing approaching velocity	Unit: r/min	0~3000
PA_042	66	Queried zero-point velocity	Unit: r/min	0~3000
PA_043	67	Homing acceleration / deceleration time	Unit: ms	0~2000
PA_044	68	Origin compensation value H	Unit: pulse	-2147483648~2147483647
PA_045	69	Origin compensation value L		

PA_046	70	Positive software limit H	Unit: pulse	-2147483648~ 2147483647																								
PA_047	71	Positive software limit L																										
PA_048	72	Negative software limit H	Unit: pulse	-2147483648~ 2147483647																								
PA_049	73	Negative software limit L																										
PA_04A	74	Internal multi-segment position Setting of absolute/relative position mode	0: Relative position mode 1: Absolute position mode	0~1																								
PA_04E	78	Control word	<table border="1"> <thead> <tr> <th>Bit</th> <th>Functions</th> <th>Description</th> </tr> </thead> <tbody> <tr> <td>Bit0</td> <td>For positioning control bit</td> <td>0: Noneffective; 1: Effective;</td> </tr> <tr> <td>Bit1</td> <td>Positioning mode bit</td> <td>0: Relative; 1: Absolute;</td> </tr> <tr> <td>Bit2</td> <td>Switching mode</td> <td>0: Ignoring the new command during a positioning motion; 1: Interrupting the current positioning motion to perform a new command</td> </tr> <tr> <td>Bit3</td> <td>JOG control bit</td> <td>0: Noneffective; 1: Effective;</td> </tr> <tr> <td>Bit4</td> <td>Homing control bit</td> <td>0: Noneffective; 1: Effective;</td> </tr> <tr> <td>Bit5</td> <td>Stopping control bit</td> <td>0: Noneffective; 1: Effective;</td> </tr> <tr> <td>Bit6</td> <td>Emergency stop control bit</td> <td>0: Noneffective; 1: Effective;</td> </tr> </tbody> </table>	Bit	Functions	Description	Bit0	For positioning control bit	0: Noneffective; 1: Effective;	Bit1	Positioning mode bit	0: Relative; 1: Absolute;	Bit2	Switching mode	0: Ignoring the new command during a positioning motion; 1: Interrupting the current positioning motion to perform a new command	Bit3	JOG control bit	0: Noneffective; 1: Effective;	Bit4	Homing control bit	0: Noneffective; 1: Effective;	Bit5	Stopping control bit	0: Noneffective; 1: Effective;	Bit6	Emergency stop control bit	0: Noneffective; 1: Effective;	0~127
Bit	Functions	Description																										
Bit0	For positioning control bit	0: Noneffective; 1: Effective;																										
Bit1	Positioning mode bit	0: Relative; 1: Absolute;																										
Bit2	Switching mode	0: Ignoring the new command during a positioning motion; 1: Interrupting the current positioning motion to perform a new command																										
Bit3	JOG control bit	0: Noneffective; 1: Effective;																										
Bit4	Homing control bit	0: Noneffective; 1: Effective;																										
Bit5	Stopping control bit	0: Noneffective; 1: Effective;																										
Bit6	Emergency stop control bit	0: Noneffective; 1: Effective;																										
PA_04F	79	Auxiliary control	<table border="1"> <thead> <tr> <th>Code</th> <th>Functions</th> </tr> </thead> <tbody> <tr> <td>0x0000</td> <td>Noneffective</td> </tr> <tr> <td>0x0100</td> <td>Restore factory parameters</td> </tr> <tr> <td>0x0200</td> <td>Save current parameters</td> </tr> <tr> <td>0x0300</td> <td>Clear current alarm</td> </tr> <tr> <td>0x0400</td> <td>Clear current position</td> </tr> <tr> <td>0x0500</td> <td>Motor enabling</td> </tr> <tr> <td>0x0600</td> <td>Motor release</td> </tr> </tbody> </table>	Code	Functions	0x0000	Noneffective	0x0100	Restore factory parameters	0x0200	Save current parameters	0x0300	Clear current alarm	0x0400	Clear current position	0x0500	Motor enabling	0x0600	Motor release									
Code	Functions																											
0x0000	Noneffective																											
0x0100	Restore factory parameters																											
0x0200	Save current parameters																											
0x0300	Clear current alarm																											
0x0400	Clear current position																											
0x0500	Motor enabling																											
0x0600	Motor release																											

### 3.5.4 Internal multi-segment position

No.	Register address (decimal)	Item	Description	Setting range
PA_050	80	Positioning Target H of Positioning Path 0	Unit: pulse	-2147483648~ 2147483647
PA_051	81	Positioning Target L of Positioning Path 0		
PA_052	82	Positioning velocity of Positioning Path 0	Unit: r/min	0~3000
PA_053	83	Positioning acceleration time of Positioning Path 0	Unit: ms	0~2000

PA_054	84	Positioning deceleration time of Positioning Path 0	Unit: ms	0~2000
PA_056	86	Positioning Target H of Positioning Path 1	Unit: pulse	-2147483648~ 2147483647
PA_057	87	Positioning Target L of Positioning Path 1		
PA_058	88	Positioning velocity of Positioning Path 1	Unit: r/min	0~3000
PA_059	89	Positioning acceleration time of Positioning Path 1	Unit: ms	0~2000
PA_05A	90	Positioning deceleration time of Positioning Path 1	Unit: ms	0~2000
PA_05C	92	Positioning Target H of Positioning Path 2	Unit: pulse	-2147483648~ 2147483647
PA_05D	93	Positioning Target L of Positioning Path 2		
PA_05E	94	Positioning velocity of Positioning Path 2	Unit: r/min	0~3000
PA_05F	95	Positioning acceleration time of Positioning Path 2	Unit: ms	0~2000
PA_060	96	Positioning deceleration time of Positioning Path 2	Unit: ms	0~2000
PA_062	98	Positioning Target H of Positioning Path 3	Unit: pulse	-2147483648~ 2147483647
PA_063	99	Positioning Target L of Positioning Path 3		
PA_064	100	Positioning velocity of Positioning Path 3	Unit: r/min	0~3000
PA_065	101	Positioning acceleration time of Positioning Path 3	Unit: ms	0~2000
PA_066	102	Positioning deceleration time of Positioning Path 3	Unit: ms	0~2000
PA_068	104	Positioning Target H of Positioning Path 4	Unit: pulse	-2147483648~ 2147483647
PA_069	105	Positioning Target L of Positioning Path 4		
PA_06A	106	Positioning velocity of Positioning Path 4	Unit: r/min	0~3000
PA_06B	107	Positioning acceleration time of Positioning Path 4	Unit: ms	0~2000
PA_06C	108	Positioning deceleration time of Positioning Path 4	Unit: ms	0~2000
PA_06E	110	Positioning Target H of Positioning Path 5	Unit: pulse	-2147483648~ 2147483647
PA_06F	111	Positioning Target L of Positioning Path 5		
PA_070	112	Positioning velocity of Positioning Path 5	Unit: r/min	0~3000
PA_071	113	Positioning acceleration time of Positioning Path 5	Unit: ms	0~2000
PA_072	114	Positioning deceleration time of Positioning Path 5	Unit: ms	0~2000
PA_074	116	Positioning Target H of Positioning Path 6	Unit: pulse	-2147483648~ 2147483647
PA_075	117	Positioning Target L of Positioning Path 6		
PA_076	118	Positioning velocity of Positioning Path 6	Unit: r/min	0~3000
PA_077	119	Positioning acceleration time of Positioning Path 6	Unit: ms	0~2000
PA_078	120	Positioning deceleration time of Positioning Path 6	Unit: ms	0~2000
PA_07A	122	Positioning Target H of Positioning Path 7	Unit: pulse	-2147483648~ 2147483647
PA_07B	123	Positioning Target L of Positioning Path 7		
PA_07C	124	Positioning velocity of Positioning Path 7	Unit: r/min	0~3000
PA_07D	125	Positioning acceleration time of Positioning Path 7	Unit: ms	0~2000
PA_07E	126	Positioning deceleration time of Positioning Path 7	Unit: ms	0~2000
PA_080	128	Positioning Target H of Positioning Path 8	Unit: pulse	-2147483648~ 2147483647
PA_081	129	Positioning Target L of Positioning Path 8		
PA_082	130	Positioning velocity of Positioning Path 8	Unit: r/min	0~3000
PA_083	131	Positioning acceleration time of Positioning Path 8	Unit: ms	0~2000
PA_084	132	Positioning deceleration time of Positioning Path 8	Unit: ms	0~2000
PA_086	134	Positioning Target H of Positioning Path 9	Unit: pulse	-2147483648~ 2147483647
PA_087	135	Positioning Target L of Positioning Path 9		
PA_088	136	Positioning velocity of Positioning Path 9	Unit: r/min	0~3000
PA_089	137	Positioning acceleration time of Positioning Path 9	Unit: ms	0~2000
PA_08A	138	Positioning deceleration time of Positioning Path 9	Unit: ms	0~2000
PA_08C	140	Positioning Target H of Positioning Path 10	Unit: pulse	-2147483648~ 2147483647
PA_08D	141	Positioning Target L of Positioning Path 10		
PA_08E	142	Positioning velocity of Positioning Path 10	Unit: r/min	0~3000
PA_08F	143	Positioning acceleration time of Positioning Path 10	Unit: ms	0~2000

PA_090	144	Positioning deceleration time of Positioning Path 10	Unit: ms	0~2000
PA_092	146	Positioning Target H of Positioning Path 11	Unit: pulse	-2147483648~ 2147483647
PA_093	147	Positioning Target L of Positioning Path 11		
PA_094	148	Positioning velocity of Positioning Path 11	Unit: r/min	0~3000
PA_095	149	Positioning acceleration time of Positioning Path 11	Unit: ms	0~2000
PA_096	150	Positioning deceleration time of Positioning Path 11	Unit: ms	0~2000
PA_098	152	Positioning Target H of Positioning Path 12	Unit: pulse	-2147483648~ 2147483647
PA_099	153	Positioning Target L of Positioning Path 12		
PA_09A	154	Positioning velocity of Positioning Path 12	Unit: r/min	0~3000
PA_09B	155	Positioning acceleration time of Positioning Path 12	Unit: ms	0~2000
PA_09C	156	Positioning deceleration time of Positioning Path 12	Unit: ms	0~2000
PA_09E	158	Positioning Target H of Positioning Path 13	Unit: pulse	-2147483648~ 2147483647
PA_09F	159	Positioning Target L of Positioning Path 13		
PA_0A0	160	Positioning velocity of Positioning Path 13	Unit: r/min	0~3000
PA_0A1	161	Positioning acceleration time of Positioning Path 13	Unit: ms	0~2000
PA_0A2	162	Positioning deceleration time of Positioning Path 13	Unit: ms	0~2000
PA_0A4	164	Positioning Target H of Positioning Path 14	Unit: pulse	-2147483648~ 2147483647
PA_0A5	165	Positioning Target L of Positioning Path 14		
PA_0A6	166	Positioning velocity of Positioning Path 14	Unit: r/min	0~3000
PA_0A7	167	Positioning acceleration time of Positioning Path 14	Unit: ms	0~2000
PA_0A8	168	Positioning deceleration time of Positioning Path 14	Unit: ms	0~2000
PA_0A A	170	Positioning Target H of Positioning Path 15	Unit: pulse	-2147483648~ 2147483647
PA_0AB	171	Positioning Target L of Positioning Path 15		
PA_0AC	172	Positioning velocity of Positioning Path 15	Unit: r/min	0~3000
PA_0A D	173	Positioning acceleration time of Positioning Path 15	Unit: ms	0~2000
PA_0AE	174	Positioning deceleration time of Positioning Path 15	Unit: ms	0~2000

### 3.5.5 Internal multi-segment velocity

No.	Register address (decimal)	Item	Description	Setting range
PA_0B0	176	Running velocity of Velocity Path 0	Unit: r/min	-3000~3000
PA_0B1	177	Acceleration time of Velocity Path 0	Unit: ms	0~2000
PA_0B2	178	Deceleration time of Velocity Path 0	Unit: ms	0~2000
PA_0B3	179	Running velocity of Velocity Path 1	Unit: r/min	-3000~3000
PA_0B4	180	Acceleration time of Velocity Path 1	Unit: ms	0~2000
PA_0B5	181	Deceleration time of Velocity Path 1	Unit: ms	0~2000
PA_0B6	182	Running velocity of Velocity Path 2	Unit: r/min	-3000~3000
PA_0B7	183	Acceleration time of Velocity Path 2	Unit: ms	0~2000
PA_0B8	184	Deceleration time of Velocity Path 2	Unit: ms	0~2000
PA_0B9	185	Running velocity of Velocity Path 3	Unit: r/min	-3000~3000
PA_0BA	186	Acceleration time of Velocity Path 3	Unit: ms	0~2000
PA_0BB	187	Deceleration time of Velocity Path 3	Unit: ms	0~2000
PA_0BC	188	Running velocity of Velocity Path 4	Unit: r/min	-3000~3000
PA_0BD	189	Acceleration time of Velocity Path 4	Unit: ms	0~2000
PA_0BE	190	Deceleration time of Velocity Path 4	Unit: ms	0~2000
PA_0BF	191	Running velocity of Velocity Path 5	Unit: r/min	-3000~3000
PA_0C0	192	Acceleration time of Velocity Path 5	Unit: ms	0~2000
PA_0C1	193	Deceleration time of Velocity Path 5	Unit: ms	0~2000

PA_0C2	194	Running velocity of Velocity Path 6	Unit: r/min	-3000~3000
PA_0C3	195	Acceleration time of Velocity Path 6	Unit: ms	0~2000
PA_0C4	196	Deceleration time of Velocity Path 6	Unit: ms	0~2000
PA_0C5	197	Running velocity of Velocity Path 7	Unit: r/min	-3000~3000
PA_0C6	198	Acceleration time of Velocity Path 7	Unit: ms	0~2000
PA_0C7	199	Deceleration time of Velocity Path 7	Unit: ms	0~2000
PA_0C8	200	Running velocity of Velocity Path 8	Unit: r/min	-3000~3000
PA_0C9	201	Acceleration time of Velocity Path 8	Unit: ms	0~2000
PA_0CA	202	Deceleration time of Velocity Path 8	Unit: ms	0~2000
PA_0CB	203	Running velocity of Velocity Path 9	Unit: r/min	-3000~3000
PA_0CC	204	Acceleration time of Velocity Path 9	Unit: ms	0~2000
PA_0CD	205	Deceleration time of Velocity Path 9	Unit: ms	0~2000
PA_0CE	206	Running velocity of Velocity Path 10	Unit: r/min	-3000~3000
PA_0CF	207	Acceleration time of Velocity Path 10	Unit: ms	0~2000
PA_0D0	208	Deceleration time of Velocity Path 10	Unit: ms	0~2000
PA_0D1	209	Running velocity of Velocity Path 11	Unit: r/min	-3000~3000
PA_0D2	210	Acceleration time of Velocity Path 11	Unit: ms	0~2000
PA_0D3	211	Deceleration time of Velocity Path 11	Unit: ms	0~2000
PA_0D4	212	Running velocity of Velocity Path 12	Unit: r/min	-3000~3000
PA_0D5	213	Acceleration time of Velocity Path 12	Unit: ms	0~2000
PA_0D6	214	Deceleration time of Velocity Path 12	Unit: ms	0~2000
PA_0D7	215	Running velocity of Velocity Path 13	Unit: r/min	-3000~3000
PA_0D8	216	Acceleration time of Velocity Path 13	Unit: ms	0~2000
PA_0D9	217	Deceleration time of Velocity Path 13	Unit: ms	0~2000
PA_0DA	218	Running velocity of Velocity Path 14	Unit: r/min	-3000~3000
PA_0DB	219	Acceleration time of Velocity Path 14	Unit: ms	0~2000
PA_0DC	220	Deceleration time of Velocity Path 14	Unit: ms	0~2000
PA_0DD	221	Running velocity of Velocity Path 15	Unit: r/min	-3000~3000
PA_0DE	222	Acceleration time of Velocity Path 15	Unit: ms	0~2000
PA_0DF	223	Deceleration time of Velocity Path 15	Unit: ms	0~2000

### 3.5.6 Factory parameters

No.	Register address (decimal)	Item	Description	Setting range
PA_100	256	Running mode (Effective after restart)	1: Open loop; 2: Closed loop;	1~2
PA_101	257	Encoder resolution	Encoder resolution	
PA_102	258	Max. effective current	The maximum current output by the drive, in mA;	
PA_103	259	Maximum current ratio under closed loop	Maximum current ratio under closed loop	
PA_104	260	Basic current ratio	Basic current ratio	
PA_105	261	Maximum current ratio under open loop	Maximum current ratio under open loop	
PA_106	262	Current ratio for locking	Current ratio for locking	
PA_107	263	Locking time	Locking time	
PA_109	265	Low-pass filtering coefficient	Low-pass filtering coefficient	
PA_10A	266	Out-of-tolerance threshold	Out-of-tolerance threshold	

PA_10B	267	Positioning accuracy threshold	Positioning accuracy threshold	
PA_10C	268	Positioning completion time	Positioning completion time	
PA_10D	269	Mean filtering coefficient	Mean filtering coefficient	
PA_10E	270	Gain adjustment ratio of current loop	Gain adjustment ratio of current loop	
PA_10F	271	Current loop Kp	Current loop Kp	
PA_110	272	Current loop Ki	Current loop Ki	
PA_111	273	Current loop Kc	Current loop Kc	
PA_112	274	LA Velocity Kp1	LA Velocity Kp1	
PA_113	275	LA Velocity Kv1	LA Velocity Kv1	
PA_114	276	Velocity node 1	Velocity node 1	
PA_115	277	LA Velocity Kp2	LA Velocity Kp2	
PA_116	278	LA Velocity Kv2	LA Velocity Kv2	
PA_117	279	velocity node 2	Velocity node 1	
PA_118	280	Velocity feedforward	Velocity feedforward	
PA_119	281	Position integral	Position integral	

### 3.6 Alarm processing

The alarm information of this drive series is identified by the number of flashes of the indicator. See the specific alarm information shown in the following table:

Number of indicator flashes	Alarm description	Troubleshooting	Reset
Flashing once every 5 seconds	Overcurrent alarm	<ol style="list-style-type: none"> <li>1. Short circuit of motor power line, check the motor for correct wiring;</li> <li>2. Motor damaged, measure the winding resistance values of Phases A and B of the motor;</li> <li>3. Drive damaged, replace the drive.</li> </ol>	Restart reset
Flashing twice every 5 seconds	Overvoltage alarm	<ol style="list-style-type: none"> <li>1. Too high voltage, measure the power supply voltage or replace the power supply;</li> <li>2. Drive damaged, replace the drive.</li> </ol>	Restart reset
Flashing thrice every 5 seconds	Undervoltage alarm	<ol style="list-style-type: none"> <li>1. Too low voltage, measure the power supply voltage or replace the power supply;</li> <li>2. Drive damaged, replace the drive.</li> </ol>	Restart reset
Flashing four times every 5 seconds	Read/write error of memory	Drive damaged, replace the drive.	Resettable
Flashing five times every 5 seconds	Position out-of-tolerance alarm	<ol style="list-style-type: none"> <li>1. Incorrect phase sequence of motor power line, check the phase sequence;</li> <li>2. Phase loss of motor power line, check the line for being disconnected or loose;</li> <li>3. Encoder disconnected;</li> <li>4. Load blocked;</li> <li>5. Too fast.</li> </ol>	Resettable

## Chapter IV Description of MODBUS RTU

### 4.1 Parameter reading command (0x03)

Command sent by master station (PLC, etc.):

Byte order	Command example	Functional symbols	Functions
1st Byte	0x01	Slave Addr	Slave address, here is 1
2nd Byte	0x03	CMD	Function code, here is 0x03, indicating that it is a command to read parameters
3rd Byte	0x00	Start AddrH	Upper 8 bits of the starting address of the read parameter
4th Byte	0x0A	Start AddrL	Lower 8 bits of the starting address of the read parameter
5th Byte	0x00	Num_High(Byte)	Upper 8 bits of the number of read parameters Note: The number here refers to how many registers (words), not how many bytes.
6th Byte	0x01	Num_Low(Byte)	Lower 8 bits of the number of read parameters
7th Byte	0Xa4	CRC_H	High bit of CRC check. CRC check refers to the CRC checksum of the 1st to the previous byte (here is the 6th byte).
8th Byte	0x08	CRC_L	Low bit of CRC check.

[For the above example: A parameter is read from the master station with the slave station address set as 1 and the starting address, as 10 (0x000A), namely, two bytes are read]

Slave station (drive) response:

Byte order	Command example	Functional symbols	Functions
1st Byte	0x01	Slave Addr	Slave address, here is 1
2nd Byte	0x03	CMD	Function code, 0x03, corresponding to the master command
3rd Byte	0x02	Data Lenth	Data length of the response, unit: bytes
4th Byte	0x00	Data0	Data 0 (high bit of the 1st register)
5th Byte	0x00	Data0	Data 0 (low bit of the 1st register)
6th Byte	0Xb8	CRC_H	High bit of CRC check. CRC check refers to the CRC checksum of the 1st to the previous byte (here is the 9th byte).
7th Byte	0x44	CRC_L	Low bit of CRC check.

[Responded data0: 0x0000;]

## 4.2 Single-register writing command (0x06)

Command sent by master station (PLC, etc.):

Byte order	Command example	Functional symbols	Functions
1st Byte	0x01	Slave Addr	Slave address, here is 1
2nd Byte	0x06	CMD	Function code, here is 0x06, indicating that it is to write a parameter command
3rd Byte	0x00	Start AddrH	Upper 8 bits of the starting address of the written parameter
4th Byte	0x70	Start AddrL	Lower 8 bits of the starting address of the written parameter
5th Byte	0x00	DATA(0)	Upper 8 bits of the written data.
6th Byte	0x14	DATA(1)	Lower 8 bits of the written data.
7th Byte	0x88	CRC_H	High bit of CRC check. CRC check refers to the CRC checksum of the 1st to the previous byte (here is the 6th byte).
8th Byte	0x1E	CRC_L	Low bit of CRC check.

[For the above example: A parameter is written from the master station with the slave station address set as 1 and the starting address, as 112(0x0070), the value is 20(0x0014)]



Slave station (drive) response:

Byte order	Command example	Functional symbols	Functions
1st Byte	0x01	Slave Addr	Slave address, here is 1
2nd Byte	0x06	CMD	Function code, 0x06, corresponding to the master command
3rd Byte	0x00	Start AddrH	Upper 8 bits of the starting address of the written parameter
4th Byte	0x70	Start AddrL	Lower 8 bits of the starting address of the written parameter
5th Byte	0x00	DATA(0)	Upper 8 bits of the written data.
6th Byte	0x14	DATA(1)	Lower 8 bits of the written data.
7th Byte	0x88	CRC_H	High bit of CRC check. CRC check refers to the CRC checksum of the 1st to the previous byte (here is the 6th byte).
8th Byte	0x1E	CRC_L	Low bit of CRC check.

### 4.3 Multi-register writing command (0x10)

Command sent by master station (PLC, etc.):

Byte order	Command example	Functional symbols	Functions
1st Byte	0x01	Slave Addr	Slave address, here is 1
2nd Byte	0x10	CMD	Function code, here is 0x10, indicating that it is to write multiple parameter commands
3rd Byte	0x00	Start AddrH	Upper 8 bits of the starting address of the written parameter
4th Byte	0xB0	Start AddrL	Lower 8 bits of the starting address of the written parameter
5th Byte	0x00	NUM_H	Upper 8 bits of the number of parameters (registers) written
6th Byte	0x02	NUM_L	Lower 8 bits of the number of parameters (registers) written
7th Byte	0x04	Data Length	The number of bytes of the parameter written is twice the number of registers
8th Byte	0x03	DATA(0)	Upper 8 bits of the first data written.
9th Byte	0xE8	DATA(0)	Lower 8 bits of the first data written.
10th Byte	0x00	DATA(1)	Upper 8 bits of the second data written.
11th Byte	0x64	DATA(1)	Lower 8 bits of the second data written.
12th Byte	0x79	CRC_H	High bit of CRC check. CRC check refers to the CRC checksum of the 1st to the previous byte (here is the 6th byte).
13th Byte	0x40	CRC_L	Low bit of CRC check.

[For the above example: 2 parameters are written from the master station with the slave station address set as 1 and the starting address, as 176(0x00B0), which are:

176(0x00B0)=1000(0x03E8)、177(0x00B1)=100(0x0064)]

Slave station (drive) response:

Byte order	Command example	Functional symbols	Functions
1st Byte	0x01	Slave Addr	Slave address, here is 1
2nd Byte	0x10	CMD	Function code, 0x10, corresponding to the master command
3rd Byte	0x00	Start AddrH	Upper 8 bits of the starting address of the written parameter

4th Byte	0xB0	Start AddrL	Lower 8 bits of the starting address of the written parameter
5th Byte	0x00	NUM_H	Upper 8 bits of the number of parameters to be written (number of registers).
6th Byte	0x02	NUM_L	Lower 8 bits of the number of parameters to be written (number of registers).
7th Byte	0x40	CRC_H	High bit of CRC check. CRC check refers to the CRC checksum of the 1st to the previous byte (here is the 6th byte).
8th Byte	0x2F	CRC_L	Low bit of CRC check.

#### 4.4 Abnormal response and error code

Regardless of the read or write command, if the slave responds abnormally, its response frame is changed. As follows

Byte order	Command example	Functional symbols	Functions
1st Byte	0x01	Slave Addr	Slave address, here is 1
2nd Byte	0x06	CMD 0x80	Highest Position 1 of function code
3rd Byte	0x04	Error Code	Error code. There are the following types:
			0x02: Illegal address
			0x03: Illegal data
0x04: Refused to execute			
4th Byte	0x10	CRC_H	High bit of CRC check. CRC check refers to the CRC checksum of the 1st to the previous byte (here is the 3rd byte).
5th Byte	0x00	CRC_L	Low bit of CRC check.